

Description

The DE-HSD-9i Multi criteria Detector is a Component of DAKSH Addressable series. This analog addressable device uses an optical Sensing chamber as well as Heat sensor to Detect Fire. Addressing of these devices shall be done manually via external Programmer.

Features

- Stable comm. technique with noise immunity.
- Soft addressable by use of address programmer.
- Dual fire alarm indicators for 360° viewing.
- Addressable –analog communication.
- Response indicator output.
- Compatible with DAKSH panel.
- Micro controller based device
- Low standby current.
- Two-wire SLC connection.
- fully confirms IS: 2189



Electrical Specifications:

Input Voltage	18 to 25V
Static Current	60 μ A (With no communication enabled)
Alarm Current	600 μ A
Installation Method	Ceiling mount
Response Indicator	Normal - Blinking Fire - Still
Sensor type	Infrared photo Sensor and Heat Sensor

Environmental Specifications:

Operational temperature range	-10°C to +70°C
Humidity	≤ 95% Relative Humidity

Mechanical Information:

Height	39mm (W/o base)
Diameter	100mm
Weight	Approx 100g
Colour	Cream White
Material	ABS Plastic

Architect/Engineer Specifications

Addressable Multi Criteria Heat cum Smoke Detector (DE-HSD-9i)

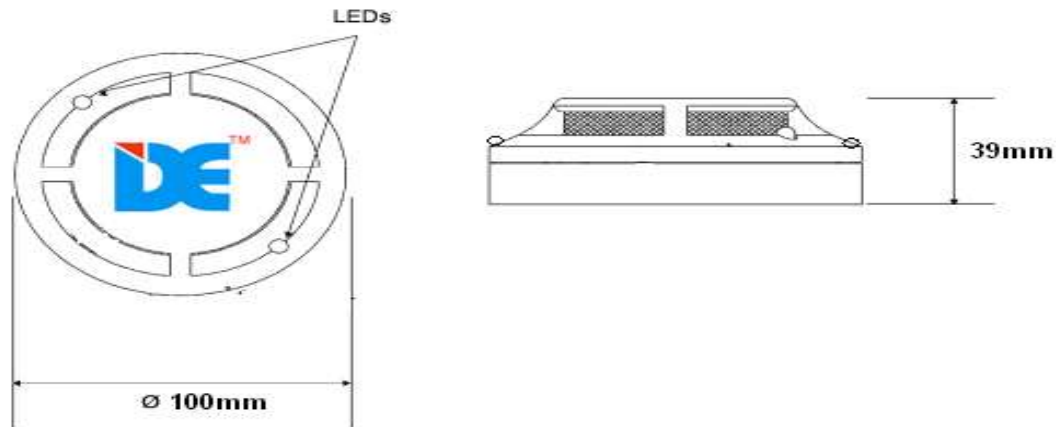

Wiring Diagrams

1. Choose suitable position to install the detector, normally on the ceiling of the center detecting area, fix the detector on it. Rotate and check whether it is firm.
2. Please connect the wires correctly as required.

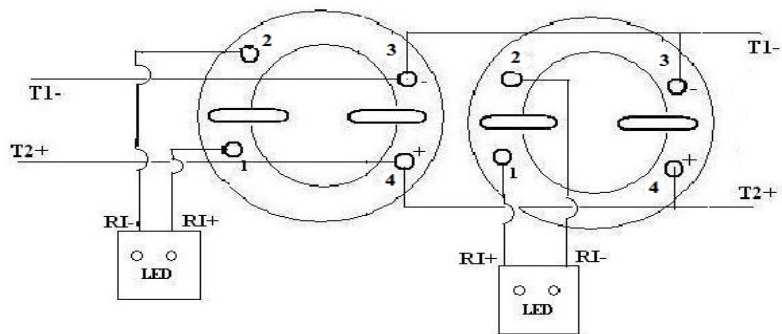

WIRING DIAGRAM

No. Function

- | | |
|---|--------------------------|
| 1 | (RI+) RESPONSE INDICATOR |
| 2 | (RI-) RESPONSE INDICATOR |
| 3 | T- (LOOP IN/ LOOP OUT) |
| 4 | T+ (LOOP IN/ LOOP OUT) |

WIRE INSTALLATION:

- All the wire installation must accord with National and local effective laws and criteria.

- All wires must have the suitable size and the wires connecting detectors and other devices must have colorful marks for avoiding connecting error. And unsuitable connection will lead to alarm error when Fire happens.

NOTES:

- This detector does not operate without electrical power. As fires frequently cause power interruption, discuss further safeguards with your local fire protection specialist.
- This detector does not sense fires in area where smoke cannot reach the detector. Smoke from fires in walls, roofs, or on the opposite side of closed doors may not reach the detector.
- Photoelectric detectors have a wide range of sensing capabilities, but are best suited for detecting slow, smoldering fires.
- To ensure proper operation, store the detector within the recommended ranges. Allow the detector to stabilize to room temperature before applying power.
- The dust cover (supplied) must remain on the detector during installation, and then be removed prior to operation; the dust cover is not a substitute for removing the detector during new construction or heavy remodeling.



**AN ISO:9001:2015
CERTIFIED COMPANY
EN 54-7**

H.O.: 19, DSIDC, Computer Complex, Scheme-1, Okhla Industrial Area, Phase-2, New Delhi-110020 (India)
Tel: +91-11-26385033, 26385390, 46515680
Email: sales@dakshglobal.com,
Web: www.dakshglobal.com

Works: B-220, ELDECO, Sidcul Industrial Park, Phase-1, Sitarganj, U.S. Nagar, Uttarakhand-262405 (India)
Tel: +91-11-26385033, 26385390, 46515680
Email: h_kundu@dakshglobal.com,
Web: www.dakshglobal.com

Note: It is essential to ensure that only known compatible components are used in a fire detection system. If in doubt, always consult the fire control panel supplier/manufacturere.