

**DESCRIPTION**

The DE-HD-9i Addressable Heat Detector is a Component of DAKSH Addressable Series. This device uses a Heat sensor to Detect fire. Addressing of these devices shall be done manually via external Programmer.

**FEATURES**

- Stable comm. technique with noise immunity.
- Addressing using handheld programmer.
- Dual fire alarm indicators for 360° viewing.
- Addressable –analog communication.
- Inbuilt response indicator output.
- Compatible with DAKSH panel.
- Micro controller based device
- Low standby current.
- Two-wire SLC connection.
- Fully confirms IS: 2189

**ELECTRICAL SPECIFICATIONS:**

Input Voltage	18 to 25V
Static Current	60µA (With no communication enabled)
Alarm Current	600µA
Installation Method	Ceiling mount
Response Indicator	Normal -       Blinking Fire -           Still
Sensor type	Heat Sensor

**ENVIRONMENTAL SPECIFICATIONS:**

Operational temperature range	-10°C +70°C
Humidity	≤ 95% Relative Humidity

## MECHANICAL INFORMATION:

Height	45mm (plus 15mm for base)
Diameter	100mm
Weight	Approx 100g
Colour	Cream White
Material	ABS Plastic
Order Code	2 wire

## ARCHITECT/ENGINEER SPECIFICATIONS

Addressable Heat Detector (DE-HD-9i)

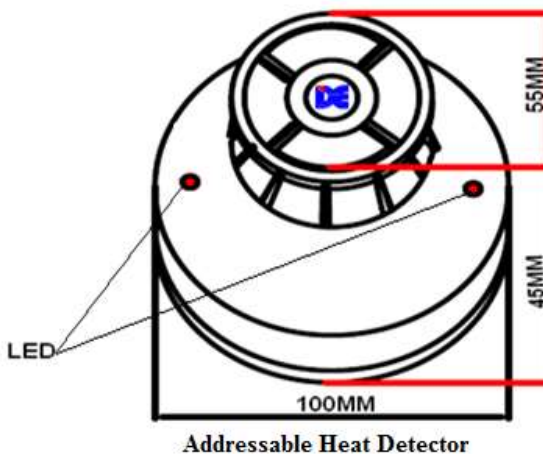
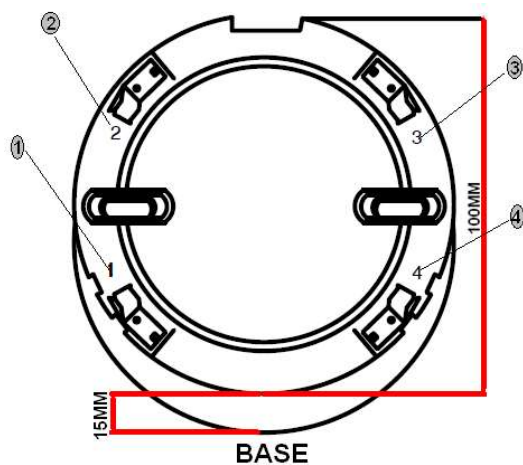

## WIRING DIAGRAMS

1. Choose suitable position to install the detector, normally on the ceiling of the center detecting area, fix the bracket on the selected position by screw, then set the detector on it. Rotate and check whether it is firm.
2. Please connect the wires as per given diagram.

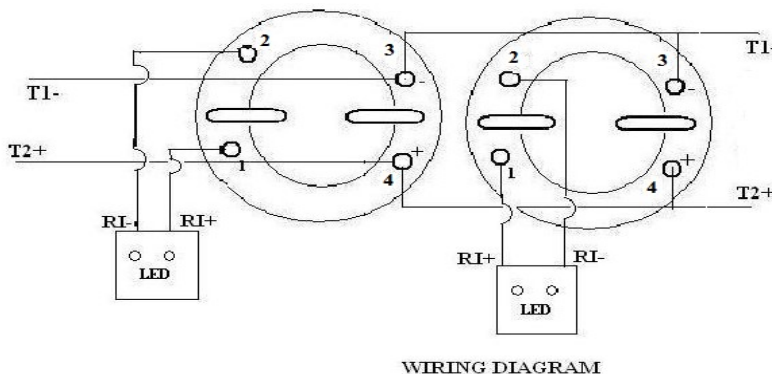

<u>No.</u>	<u>Function</u>
1	(RI+) Response Indicator
2	(RI-) Response Indicator
3	T – (LOOP IN/ LOOP OUT)
4	T + (LOOP IN/ LOOP OUT)

## WIRE INSTALLATION:

- All the wire installation must according to National and local effective laws and criteria.
- All wires must have the suitable gauge and must follow NFPA guidelines.
- Two different colored wires must be used to avoid wiring error.

## Notes:

- This detector does not sense fires in area where smoke cannot reach the detector. Smoke from fires in walls, roofs, or on the opposite side of closed doors may not reach the detector.
- Photoelectric detectors have a wide range of sensing capabilities, but are best suited for detecting slow, smoldering fires.
- To ensure proper operation, store the detector within the recommended ranges. Allow the detector to stabilize to room temperature before applying power.
- The dust cover (supplied) must remain on the detector during installation, and then be removed prior to operation; the dust cover is not a substitute for removing the detector during new construction or heavy remodeling.



**AN ISO:9001:2015  
CERTIFIED COMPANY  
EN 54-7**

H.O.:19, DSIDC, Computer Complex, Scheme-1, Okhla  
Industrial Area, Phase-2, New Delhi-110020 (India)

Tel: +91-11-26385033, 26385390, 46515680

Email: [ase99india@yahoo.co.in](mailto:ase99india@yahoo.co.in)

Web: [www.dakshglobal.com](http://www.dakshglobal.com)

**Works:** B-220, ELDECO, Sidcul Industrial Park, Phase-1,  
Sitarganj, U.S. Nagar, Uttarakhand-262405 (India)

Tel: +91-11-26385033, 26385390, 46515680

Mob: +91-9811937979

Email: [h\\_kundu@dakshglobal.com](mailto:h_kundu@dakshglobal.com),

Web: [www.dakshglobal.com](http://www.dakshglobal.com)

**Note:** It is essential to ensure that only known compatible components are used in a fire detection system. If in doubt, always consult the fire control panel supplier/manufacture.